



APT



POWER TOOLS BROCHURE

The Name You Can Trust
www.apt-international.com

20V POWER X

CORDLESS PLATFORM LI-ION

BATTERIES
DW5000202



- 2.0 AH
- BATTERY DISPLAY
- SAFETY FUSE

- 4.0 AH
- BATTERY DISPLAY
- SAFETY FUSE

DW5000204



CHARGERS

DW5500202



DW5500204



- 2.0 AH
- FAST CHARGE

- 4.0 AH
- FAST CHARGE

DW0100132 DRILL DRIVER

- 2.0 AH
- APT BATTERY
- METAL Ø13 MM
- WOOD Ø27 MM
- #2
- 24
- Ø 8 MM



-Max. torque 40 Nm
-No-load speed 0-400/0-1700 rpm (gear1/gear2)

DW0320218 IMPACT DRIVER

- 3.0 AH
- APT BATTERY
- 6.35 HEX
- Ø 8 MM



-Max. torque 45 Nm
-No-load speed 0-1500 rpm

DW0501154 ANGLE GRINDER



- 4.0 AH
- APT BATTERY
- 2 POSITION SIDE HANDLE
- Ø 115 MM

-No-load speed 8500

DW0700122 DRYWALL SCREWDRIVER

- 2.0 AH
- APT BATTERY
- 6.35 HEX
- TY



-Max. torque 5 Nm
-No-load speed 0-4000 rpm

DW0420435 IMPACT WRENCH

- 4.0 AH
- APT BATTERY
- 1/2" Anvil



-Max. torque 350 Nm
-No-load speed 0-2000 rpm
-Impact rate 0-3000 bpm

DW0600062 MULTI-TOOL



- 2.0 AH
- APT BATTERY
- Ø6
- OSCLLATION ANGLE UP

-No-load speed 8000-16000 rpm

DW0800802 JIG SAW

- 2.0 AH
- APT BATTERY
- 45° 45°
- WOOD 80 MM
- METAL 5 MM
- 3 2 1 0
- B



-Stroke length 20 mm
-No-load stroke rate 0-2700 spm

DW0900204 CIRCULAR SAW

- 4.0 AH
- APT BATTERY
- BLADE Ø165 MM
- WOOD 90° 53 MM
- WOOD 45° 38 MM
- BRAKE



-No-load speed 0-3500

DW1000222 RECIPROCATING SAW

- 2.0 AH
- APT BATTERY
- 45° 45°



-Max. torque 5 Nm
-No-load speed 0-4000 rpm

AH8125-DC20 CERAMIC VIBRATOR

- 4.0 AH
- APT BATTERY
- WATER LEVEL
- PAD SIZE Ø5.1"



-Vibration frequency 200 Hz (12000 rpm)
-Adsorption capacity 110 lbs./45 kg
-Continuous discharge time 60 mins

LED STANDING LIGHTS

DW0900204

- APT BATTERY
- 2.0 AH
- 5 WATT
- 300 LM
- 150 LM



DW3000102

- APT BATTERY
- 2.0 AH
- 10 WATT
- 1000 LM
- 500 LM



DW3000202

- APT BATTERY
- 2.0 AH
- 20 WATT
- 2000 LM
- 900 LM



-Focus adjustment
-180° adjustable angle

**DW15105
12V LI-ION CORDLESS DRILL DRIVER**



-Max. torque 25 Nm
-No-load speed 0-350/0-1350 rpm (gear1/gear2)



**DW15555
18V LI-ION CORDLESS DRILL DRIVER**

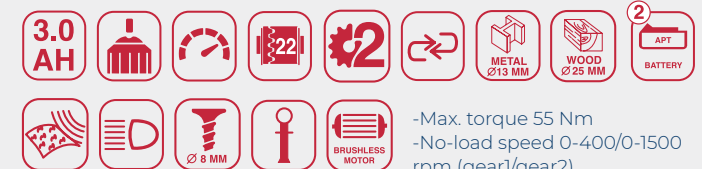

-Max. torque 55 Nm
-No-load speed 0-400/0-1500 rpm (gear1/gear2)



**DW15310
14.4V LI-ION DRILL DRIVER**



-Max. torque 27 Nm
-No-load speed 0-400/0-1450 rpm (gear1/gear2)

**DW15715
18V LI-ION CORDLESS IMPACT WRENCH**



-Max. torque 240 Nm
-No-load speed 0-2200 rpm
-Impact rate 0-3400 bpm



**DW15515
18V LI-ION DRILL DRIVER**

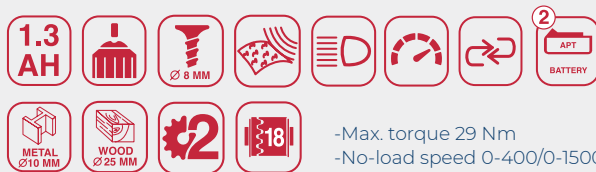

-Max. torque 29 Nm
-No-load speed 0-400/0-1500 (gear1/gear2)



**DW15725
18V LI-ION CORDLESS DRILL DRIVER**



-Max. torque 240 Nm
-No-load speed 0-2200 rpm
Impact rate 0-3400 bpm



**DW15545
18V LI-ION CORDLESS DRILL DRIVER**



-Max. torque 45 Nm
-No-load speed 0-400/0-1500 (gear1/gear2)



**AH8125-DC12
12V LI-ION CORDLESS CERAMIC VIBRATOR**

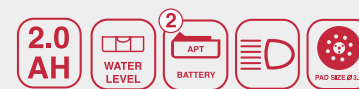

-Vibration frequency 200 Hz (12000 rpm)
-Adsorption capacity 100 lbs./45 kg
-Continuous discharge time 45 mins



DRILL DRIVERS



**DW55205
DRILL MACHINE HOLDER**



**DW01215
400W ELECTRICAL
DRILL DRIVER**

-Power Input 400 watt
-No-load speed 3400 rpm



**750W ELECTRICAL
IMPACT DRILL**

-Power Input 750 watt
-No-load speed 3000 rpm



**DW01315
450W ELECTRICAL
DRILL DRIVER**

-Power Input 450 watt
-No-load speed 3400 rpm



-Power Input 850 watt
-No-load speed 3000 rpm
-Impact Rate 48000 bpm



**DW02655
850W ELECTRICAL
IMPACT DRILL**



**DW01520
500W ELECTRICAL
RIGHT ANGLE
DRILL DRIVER**



-Power Input 500 watt
-No-load speed 1200 rpm

**DW02795
1050W ELECTRICAL
IMPACT DRILL**



-Power Input 1050 watt
-No-load speed 2800 rpm
-Impact Rate 44800 bpm



**DW02635
650W ELECTRICAL
IMPACT DRILL**

-Power Input 650 watt
-No-load speed 3000 rpm



-Power Input 1050 watt
-No-load speed 1100/3000 rpm
-Impact Rate 16500/45000 bpm

**DW02775
1050W ELECTRICAL
IMPACT DRILL**

ROTARY HAMMERS

**DW26QCC
800W SDS-PLUS**

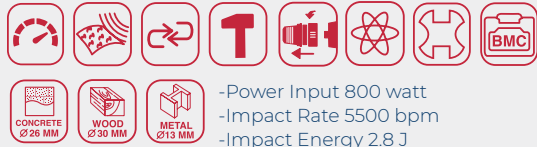

-Power Input 800 watt
-Impact Rate 5500 bpm
-Impact Energy 2.8 J

**DW36DT
1500W SDS-PLUS**



-Power Input 1500 watt
-Impact Rate 1100-2700 bpm
-Impact Energy 5 J

**DW2621
800W SDS-PLUS**



-Power Input 800 watt
-Impact Rate 5500 bpm
-Impact Energy 2.8 J

**DW36HT
1500W SDS-PLUS**



-Power Input 1500 watt
-Impact Rate 1000-3000 bpm
-Impact Energy 5 J

**DW2601
800W SDS-PLUS**



-Power Input 800 watt
-Impact Rate 4900 bpm
-Impact Energy 3 J



-Power Input 1500 watt
-Impact Rate 3600 bpm
-Impact Energy 5 J

**DW36PT
1500W SDS-PLUS**

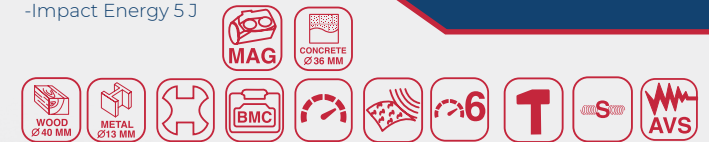

**DW26G-V2
850W SDS-PLUS**



-Power Input 850 watt
-Impact Rate 1000 bpm
-Impact Energy 4.5 J

**DW40B
1250W SDS-MAX**



-Power Input 1250 watt
-Impact Rate 2800 bpm
-Impact Energy 10 J

**DW32HT
1250W SDS-PLUS**



-Power Input 1250 watt
-Impact Rate 1200-4200 bpm
-Impact Energy 5 J

-Power Input 1700 watt
-Impact Rate 850-1900 bpm
-Impact Energy 27 J

**DW50A2T
1700W SDS-MAX**



DEMOLITION BREAKERS

METAL WORKING

**DW10C - 1010W
DEMOLITION BREAKER**

**DW05215-V2
600W ANGLE GRINDER 4.5"**



-Power Input 1010 watt
-Impact Rate 2900 bpm
-Impact Energy 10J



-Power input 600 watt
-No-load speed 11000 rpm



**DW10D - 1350W
DEMOLITION BREAKER**

-Power Input 1350 watt
-Impact Rate 2900 bpm
-Impact Energy 10J



**DW05340-V2
850W ANGLE GRINDER 5"**

-Power input 850 watt
-No-load speed 11000 rpm



**DW15D - 1300W
DEMOLITION BREAKER**



-Power Input 1300 watt
-Impact Rate 2400 bpm
-Impact Energy 20J



**DW05372
1150W ANGLE GRINDER 5"**

-Power input 1150 watt
-No-load speed 11000 rpm



-Power Input 1500 watt
-Impact Rate 1500 bpm
-Impact Energy 40J

**DW65 - 1500W
DEMOLITION BREAKER**



**DW05370-V2
1150W ANGLE GRINDER 5"**

-Power input 1150 watt
-No-load speed 11000 rpm



**DW45 - 1700W
DEMOLITION BREAKER**

-Power Input 1700 watt
-Impact Rate 1300 bpm
-Impact Energy 45J



**DW05555
1500W ANGLE GRINDER 7"**

-Power input 1500 watt
-No-load speed 8500 rpm



**DW05665
2600W ANGLE GRINDER 9"**



-Power input 2600 watt
-No-load speed 8500 rpm



**DW06416
170W MINI CRAFT**

-Power input 170 watt
-No-load speed 8000-32000 rpm
-Max chuck capacity 3.2 mm
-Accessories set



**DW05625-V2
2200W ANGLE GRINDER 9"**

-Power input 2200 watt
-No-load speed 6000 rpm



**DW06419
200W MINI CRAFT**

-Power input 200 watt
-No-load speed 10000-40000 rpm
-Max chuck capacity 3.2 mm
-Accessories set



**DW06350-V2
1200W POLISHER 7"**



-Power input 1200 watt
-No-load speed 600-3000 rpm



**DW07351
2700W CUT OFF SAW 14"**

-Power input 2700 watt
-No-load speed 4000 rpm

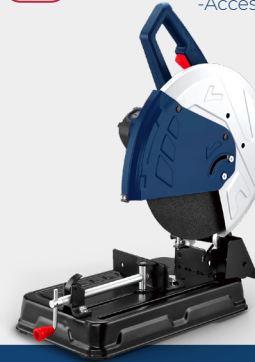

**DW06300
720W ORBITAL POLISHER 6"**

-Power input 720 watt
-No-load speed 2100-5000 rpm



**DW07353
3000W CUT OFF SAW 14"**

-Power input 3000 watt
-No-load speed 3600 rpm



**DW06412
135W MINI CRAFT**



-Power input 135 watt
-No-load speed 10000-32000 rpm
-Max chuck capacity 3.2 mm
-Accessories set



**DW06512
300W MULTI TOOL**

-Power input 300 watt
-No-load speed 15000-22000 rpm



WOOD WORKING



**DW07405
570W JIG SAW**



- Power input 570 watt
- No-load speed 3000 rpm



**DW07455
800W JIG SAW**



- Power input 800 watt
- No-load speed 3000 rpm



**DW08490
2100W ELECTRIC ROUTER**



- Input power 2100 watt
- No-load speed 9000-22000 rpm
- Plunge capacity up to 70 mm



**DW07220-V2
1200W CIRCULAR SAW 7 1/4"**

- Power input 1200 watt
- No-load speed 4700 rpm



**DW08204
300W SHEET SANDER**



- Input power 300 watt
- No-load speed 6000-12000 rpm
- Belt dimensions 230x115 mm



**DW08490
2100W ELECTRIC PLANER**

- Power input 560 watt
- No-load speed 16000 rpm
- Planing width 82 mm



**DW07340
2200W CIRCULAR SAW 9"**



- Power input 2200 watt
- No-load speed 4500 rpm



**DW07705
900W MITRE SAW 7 1/4"**



-Power input 900 watt
-No-load speed 5500 rpm



**DW07745
1800W MITRE SAW 10"**



-Power input 1800 watt
-No-load speed 2950 rpm

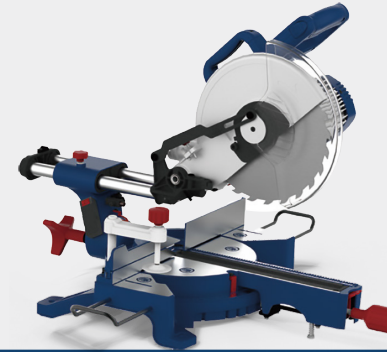

**DW07716
1200W MITRE SAW 8"**



-Power input 1200 watt
-No-load speed 4500 rpm

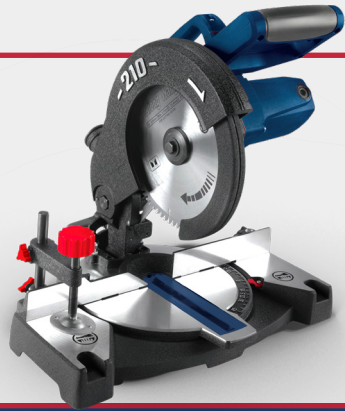

**DW07751
2200W MITRE SAW 12"**



-Power input 2200 watt
-No-load speed 4000 rpm



**DW07742
1800W MITRE SAW 10"**

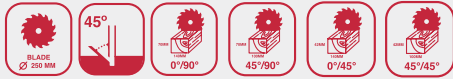

-Power input 1800 watt
-No-load speed 3000 rpm

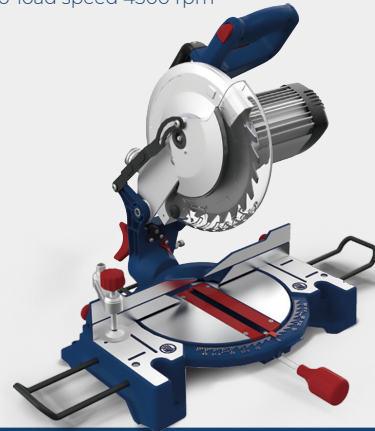

**DW07762
1800W MITRE SAW 12"**

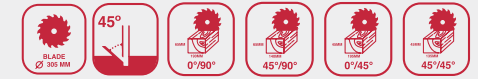

-Power input 1800 watt
-No-load speed 3500 rpm

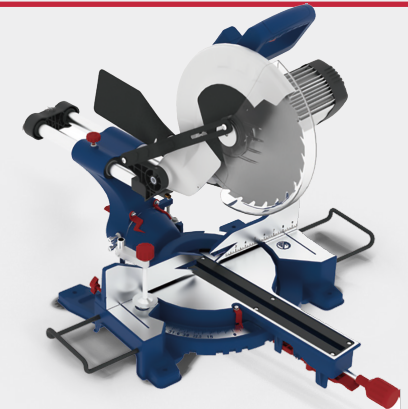

**DW07743
2000W MITRE SAW 10"**



-Power input 2000 watt
-No-load speed 5000 rpm



**DW07765
1800W MITRE SAW 12"**



-Power input 1800 watt
-No-load speed 3500 rpm

OTHER TOOLS

**DW09320A-V2
450W ELECTRIC BLOWER**



-Power input 450 watt
-No-load speed 13000 rpm
-Double function (Blowing/Suction)



**DW09520
1220W ELECTRIC MIXER**



-Power input 1220 watt
-No-load speed 800 rpm



**DW09370-V2
600W ELECTRIC BLOWER**



-Power input 600 watt
-No-load speed 5000-15000 rpm
-Double function (Blowing/Suction)



**DW08249
710W DRYWALL AND
CEILING SWIVEL SANDER**



-Power input 710 watt
-No-load speed 600-1500 rpm



**DW09800
650W ELECTRIC BLOWER**



-Power input 650 watt
-No-load speed 14000 rpm
-Double function (Blowing/Suction)



**DW08252
820W DRYWALL SANDER**



-Power input 820 watt
-No-load speed 600-1900 rpm



**DW09220
1500W HEAT GUN**



-Power input 1500 watt



**DW07515
2200W ELECTRIC
CHAINSAW**



-Power input 2200 watt
-Idle speed 6000 rpm



**DW09250
2000W HEAT GUN**



-Power input 2000 watt



**DW10020
600W ELECTRIC HEDGE
TRIMMER**



-Power input 600 watt
-Idle speed 3300 rpm

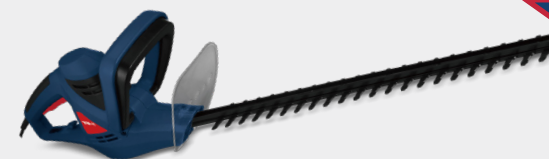



AFT

